

APPROX WEIGHT: 5.57 lbs.
 DOES NOT INCLUDE WEIGHT OF POWER OR PACKAGING!!!

HANDRAIL BASE / SUPPORT (SINGLE) - VDKR-P101, SSG-9, SSG-11

ANY ADDITIONS, DELETIONS, OR OMISSIONS MUST BE CORRECTED ON THIS DRAWING AS THIS DRAWING WILL BE CONSIDERED ALL INCLUSIVE

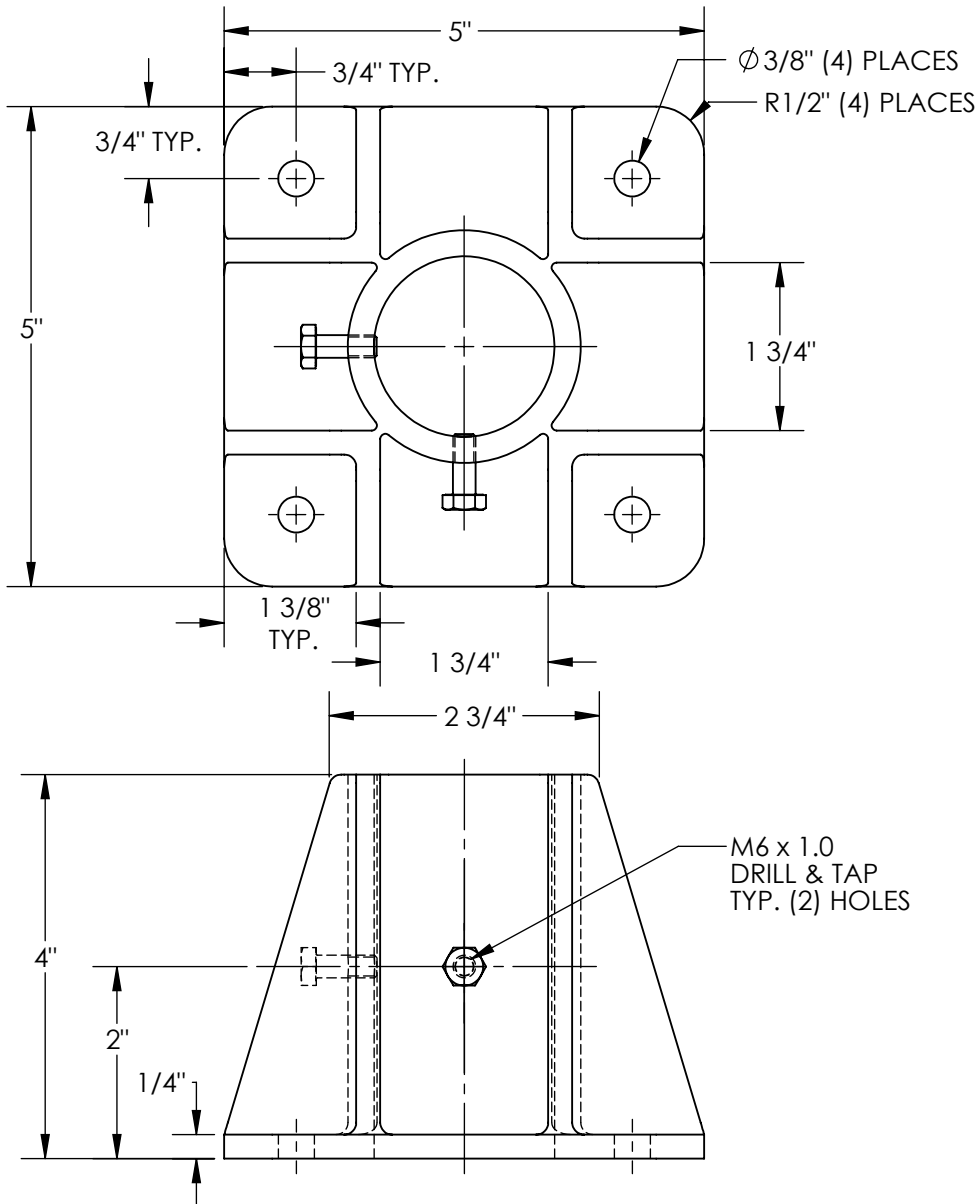

ALL GRAPHICS PROVIDED ARE FOR REFERENCE ONLY. IF CERTAIN DIMENSIONS ARE CRITICAL PLEASE VERIFY THOSE DIMENSIONS WITH YOUR SALESPERSON

DIMENSION TOLERANCE ± 1/4"

STANDARD FEATURES

- MODEL NUMBER: VDKR-P101, SSG-9, SSG-11
- OVERALL WIDTH: 5"
- OVERALL LENGTH: 5"
- OVERALL HEIGHT: 4"
- ZINC PLATED FINISH

SPECIAL FEATURES

NONE

APPROVAL	I, THE UNDERSIGNED, AGREE THAT THE PRODUCT AS REPRESENTED SATISFIES DESIGN AND DIMENSION REQUIREMENTS. I ALSO ACKNOWLEDGE MY DUTY TO CONFIRM PRODUCT AND INSTALLATION COMPLIANCE WITH ALL APPLICABLE FEDERAL, STATE AND LOCAL REGULATIONS AND STANDARDS.	
	UNITS REQUIRING APPROVAL DRAWINGS OR MODIFIED ARE NON-RETURNABLE <input type="checkbox"/> As drawn <input type="checkbox"/> As marked	
	Signed: _____	Date: _____
LEAD TIME WILL START UPON RECEIPT OF SIGNED APPROVAL DRAWING		

DISTRIBUTOR'S NAME:		P.O.#
VESTIL MANUFACTURING		X
DRAWN BY: BJB		W.O.#
DATE: 10/8/14		X
REFERENCE: X	SCALE: 1:2	SALES: X
QUOTED LEAD TIME: X	QUOTE # X	FILE NAME:
		23-007-549